



Features and Benefits

Center frequency: 311MHz
I.L: 2.8dB Max.
Operating temperature: -40°C to +85°C
Size: 3x3x1.4mm
Package type: Surface Mount



Typical Applications

IOT
Cellular
Telecom
4G/LTE
Wireless Communication
WLAN
Base Station
Radar

Mechanical Drawing & Pin Connections

Drawing No: MD240080-1

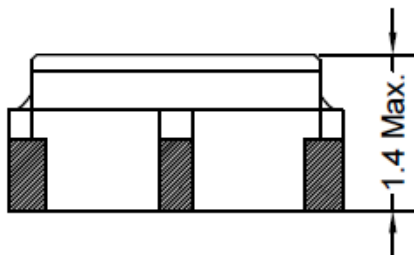
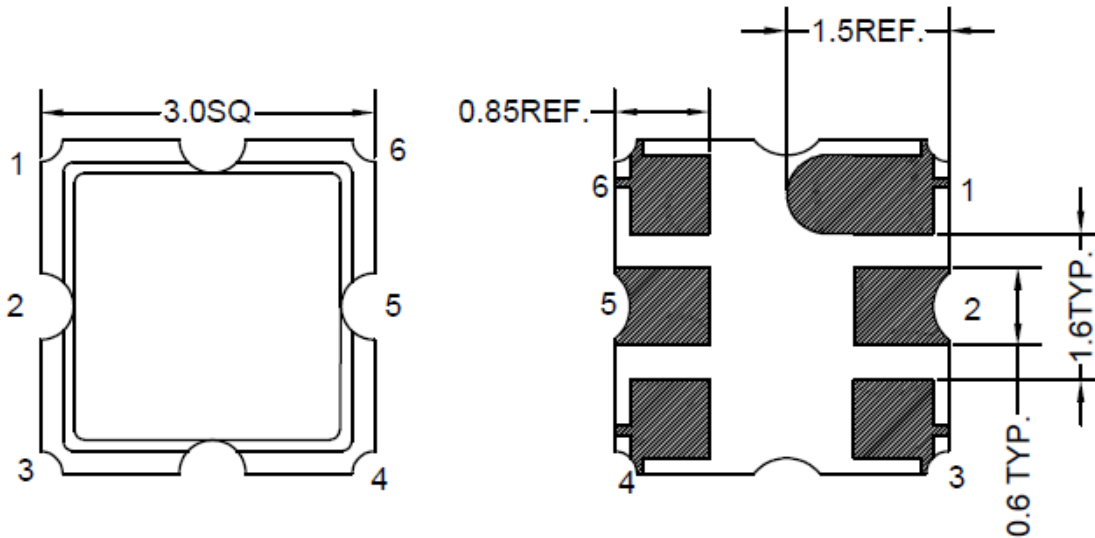

PIN	Function
#2	INPUT
#5	OUTPUT
Others	GND

Unit in mm
1mm = 0.0394 inches
Not Specified Tolerance: ±0.2mm



Specifications

Parameter		Min.	Typical	Max.	Units
Center Frequency	Fc		311		MHz
Insertion Loss (310.5~311.5 MHz)	IL		1.7	2.8	dB
Amplitude Ripple (310.5~311.5 MHz)			0.3	1.5	dB
VSWR (310.5~311.5 MHz)			1.3	2.2	
Attenuation (Reference level from 0 dB)					
261~285	MHz	50	62		dB
285~295	MHz	40	57		dB
335~361	MHz	40	45		dB
Temperature Coefficient of Frequency			-36		ppm/k
Input Power Level			10		dBm
DC Voltage			3		V
Operating Temperature Range		-40		+85	°C
Storage Temperature Range		-40		+85	°C