



**GAWJAMfcbg**

Parameter	Units	Min.	Typical	Max.
Center Frequency (Fc)	MHz		113	
Insertion Loss (IL)	dB		8.0	9.0
3dB Bandwidth	MHz	10	12	
20dB Bandwidth	MHz		14	
Passband Ripple Fc+/- 5MHz	dB		0.7	3.0
Group Delay Variation Fc+/- 5MHz	nsec		100	
Absolute Group Delay at Fc	usec		1.27	
Attenuation (Reference level from Min IL)				
10-93MHz	dB	40	45	
133-500MHz	dB	40	45	
Temperature Coefficient	ppm/°C		-94	
Source Impedance	Ohm		50	
Load Impedance	Ohm		50	
Ambient Temperature	°C		25	
Input Power Level	dBm			+10
Maximum DC Voltage	V			10
Operating Temperature Range	°C	-40		+85
Storage Temperature Range	°C	-40		+85
Moisture Sensitivity Level		Level 1 (MSL1)		

Electrostatic Sensitive Device

RoHS Compliant

**Mechanical Drawing & Pin Connections**

**Drawing No: MD& \$\$\$)!%**

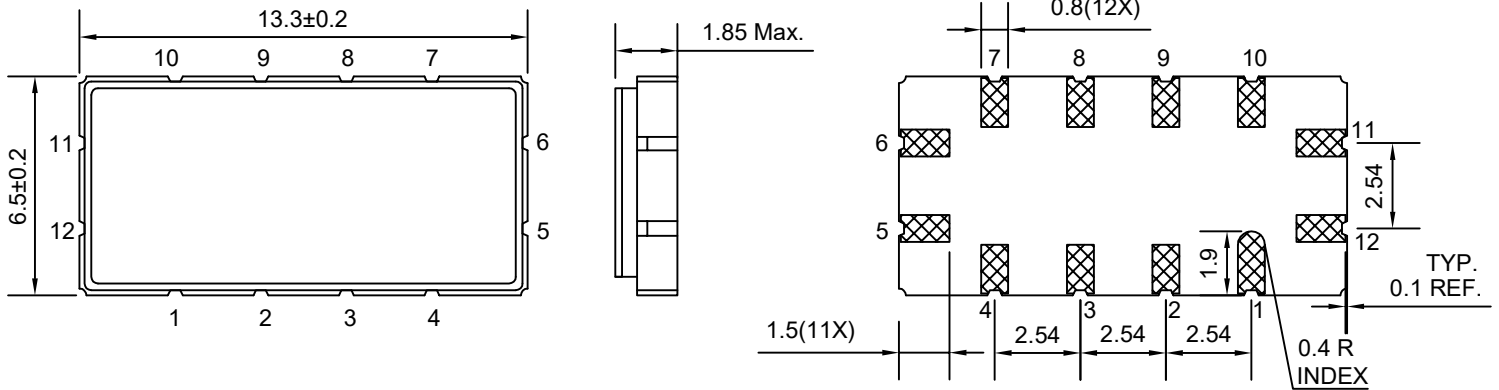

PIN #	Function
11	RF Input
5	RF Output
12	Ground
6	Ground
1,2,3,4,7,8,9,10	Ground

Unit in mm  
 1mm = 0.0394 inches